

Morskate®

Gedreven door techniek



De status van een machine op je smartphone?

De Beegle: ons plug & play machine monitoring systeem

Meer weten? www.beegle.nl

Morskate®





Piede in Acciaio Zincato

VULCANIZZATO

Caratteristiche: BASE VULCANIZZATA CON FISSAGGIO Ø 60,
STELO SNODATO 10°

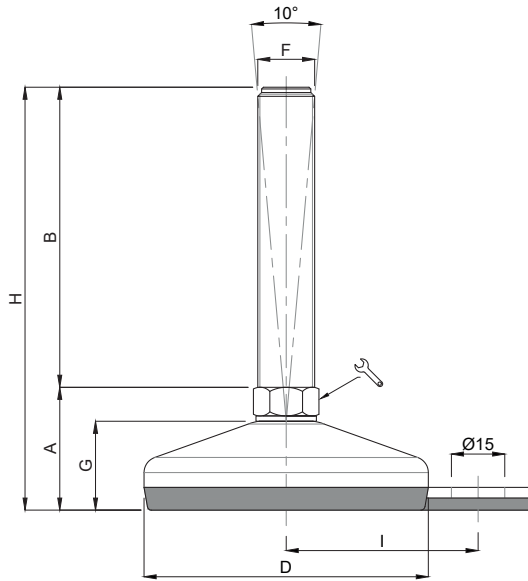
Features: VULCANIZED BOLT/DOWN BASE Ø 60, 10° ARTICULATED STEM



CODICE - CODE	descrizione description	DIMENSIONI PRINCIPALI - MAIN DIMENSIONS								CARICO STATICO STATIC LOAD NEWTON
		A	B	D		F	G	H	I	
25850/F	M10X50	32	50	Ø 60	14	M10	22	82	45	7000
25852/F	M10X100	32	100	Ø 60	14	M10	22	132	45	7000
25860/F	M12X50	32	50	Ø 60	14	M12	22	82	45	7000
25862/F	M12X100	32	100	Ø 60	14	M12	22	132	45	7000
25864/F	M12X150	32	150	Ø 60	14	M12	22	182	45	7000
25870/F	M14X50	32	50	Ø 60	14	M14	22	82	45	7000
25872/F	M14X100	32	100	Ø 60	14	M14	22	132	45	7000
25874/F	M14X150	32	150	Ø 60	14	M14	22	182	45	7000
25880/F	M16X75	32	75	Ø 60	16	M16	22	107	45	7000
25882/F	M16X100	32	100	Ø 60	16	M16	22	132	45	7000
25884/F	M16X150	32	150	Ø 60	16	M16	22	182	45	7000
25886/F	M16X200	32	200	Ø 60	16	M16	22	232	45	7000
25890/F	M20X75	33	75	Ø 60	20	M20	22	108	45	7000
25892/F	M20X100	33	100	Ø 60	20	M20	22	133	45	7000
25894/F	M20X150	33	150	Ø 60	20	M20	22	183	45	7000
25896/F	M20X200	33	200	Ø 60	20	M20	22	233	45	7000
25898/F	M20X250	33	250	Ø 60	20	M20	22	283	45	7000

• Materiale base e stelo: acciaio zincato FE
Gomma vulcanizzata NBR 80 shore

• I valori dei carichi sopra riportati sono calcolati in condizioni statiche alla metà della lunghezza dello stelo filettato. Qualora s'intendesse utilizzare i supporti in presenza di vibrazioni o carichi in movimento, tali valori dovranno essere adeguatamente ridotti. Per ulteriori chiarimenti consultare il nostro ufficio tecnico.
Ogni nostra responsabilità decade in caso di manomissioni o modifiche dei componenti

• Base material: galvanized steel C40
Screw material: galvanized steel
Pad: vulcanized rubber NBR 80 shore

• Load values above mentioned have to be considered referring to static conditions calculated at the half of the screw length. In conditions of vibrations or in presence of dynamic loads these values should be reduced. For further information consult our technical office.
We cannot accept responsibility for mounts that have been tampered or modified

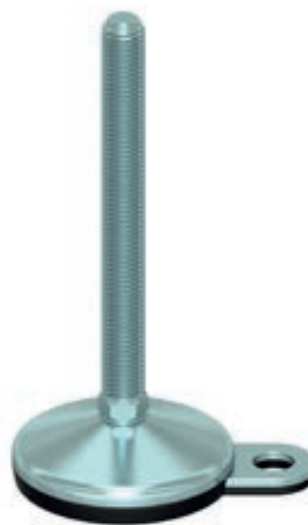
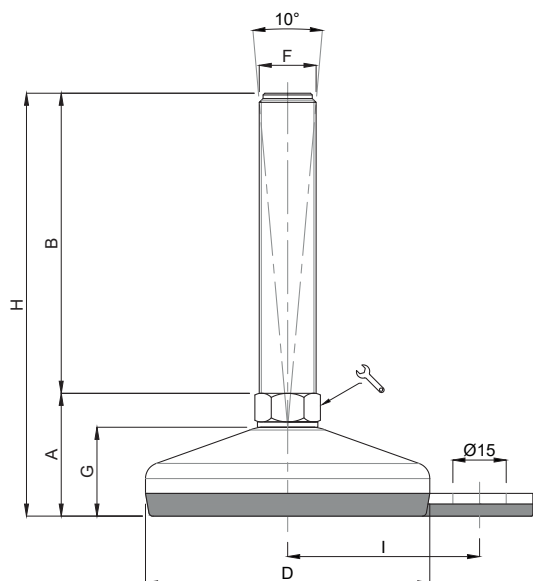

CODICE - CODE	descrizione description	DIMENSIONI PRINCIPALI - MAIN DIMENSIONS								CARICO STATICO STATIC LOAD NEWTON
		A	B	D	🔑	F	G	H	I	
26000/F	M10x50	35	50	Ø 80	14	M10	25	85	54	10000
26004/F	M10x100	35	100	Ø 80	14	M10	25	135	54	10000
26010/F	M12x50	35	50	Ø 80	14	M12	25	85	54	10000
26014/F	M12x100	35	100	Ø 80	14	M12	25	135	54	10000
26018/F	M12x150	35	150	Ø 80	14	M12	25	185	54	10000
26022/F	M14x50	35	50	Ø 80	14	M14	25	85	54	10000
26024/F	M14x100	35	100	Ø 80	14	M14	25	135	54	10000
26028/F	M14x150	35	150	Ø 80	14	M14	25	185	54	10000
26034/F	M16x75	35	50	Ø 80	16	M16	25	85	54	10000
26036/F	M16x100	35	100	Ø 80	16	M16	25	135	54	10000
26040/F	M16x150	35	150	Ø 80	16	M16	25	185	54	10000
26042/F	M16x200	35	200	Ø 80	16	M16	25	235	54	10000
26050/F	M20x75	36	75	Ø 80	20	M20	25	111	54	10000
26052/F	M20x100	36	100	Ø 80	20	M20	25	136	54	10000
26054/F	M20x150	36	150	Ø 80	20	M20	25	186	54	10000
26058/F	M20x200	36	200	Ø 80	20	M20	25	236	54	10000
26070/F	M24x75	36	75	Ø 80	24	M24	25	111	54	10000
26072/F	M24x100	36	100	Ø 80	24	M24	25	136	54	10000
* 26076/F	M24x150	36	150	Ø 80	24	M24	25	186	54	10000
* 26080/F	M24x200	36	200	Ø 80	24	M24	25	236	54	10000

* Disponibile con Filettatura a passo fine. Aggiungere "/P2" al codice
Available with Thin pitch thread. Please, add "/P2" to the code

• Materiale base e stelo: acciaio zincato FE
Gomma vulcanizzata NBR 80 shore

• I valori dei carichi sopra riportati sono calcolati in condizioni statiche alla metà della lunghezza dello stelo filettato. Qualora s'intendesse utilizzare i supporti in presenza di vibrazioni o carichi in movimento, tali valori dovranno essere adeguatamente ridotti. Per ulteriori chiarimenti consultare il nostro ufficio tecnico.
Ogni nostra responsabilità decade in caso di manomissioni o modifiche dei componenti

• Base material: galvanized steel C40
Screw material: galvanized steel
Pad: vulcanized rubber NBR 80 shore

• Load values above mentioned have to be considered referring to static conditions calculated at the half of the screw length. In conditions of vibrations or in presence of dynamic loads these values should be reduced. For further information consult our technical office.
We cannot accept responsibility for mounts that have been tampered or modified

Piede in Acciaio Zincato

VULCANIZZATO

Caratteristiche: BASE VULCANIZZATA CON FISSAGGIO Ø100,
STELO SNODATO 10°

Features: VULCANIZED BOLT/DOWN BASE Ø 100, 10° ARTICULATED STEM

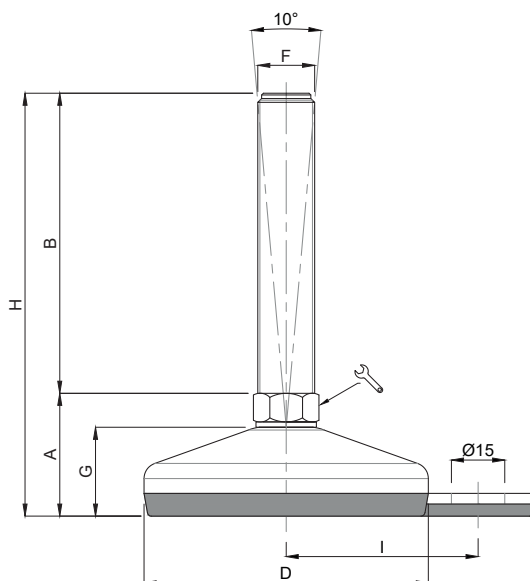

CODICE - CODE	descrizione description	DIMENSIONI PRINCIPALI - MAIN DIMENSIONS								CARICO STATICO STATIC LOAD NEWTON
		A	B	D		F	G	H	I	
26090/F	M16x75	37,5	75	Ø100	16	M16	28	112,5	69	15000
26092/F	M16x100	37,5	100	Ø100	16	M16	28	137,5	69	15000
26096/F	M16x150	37,5	150	Ø100	16	M16	28	187,5	69	15000
26100/F	M16x200	37,5	200	Ø100	16	M16	28	237,5	69	15000
26110/F	M20x75	38,5	75	Ø100	20	M20	28	113,5	69	15000
26112/F	M20x100	38,5	100	Ø100	20	M20	28	138,5	69	15000
26116/F	M20x150	38,5	150	Ø100	20	M20	28	188,5	69	15000
26120/F	M20x200	38,5	200	Ø100	20	M20	28	238,5	69	15000
26124/F	M20x250	38,5	250	Ø100	20	M20	28	288,5	69	15000
26130/F	M24x100	38,5	100	Ø100	24	M24	28	138,5	69	15000
* 26134/F	M24x150	38,5	150	Ø100	24	M24	28	188,5	69	15000
* 26140/F	M24x200	38,5	200	Ø100	24	M24	28	238,5	69	15000
26144/F	M24x250	38,5	250	Ø100	24	M24	28	288,5	69	15000
26150/F	M30x100	39,5	100	Ø100	30	M30	28	139,5	69	15000
* 26154/F	M30x150	39,5	150	Ø100	30	M30	28	189,5	69	15000
* 26158/F	M30x200	39,5	200	Ø100	30	M30	28	239,5	69	15000
26162/F	M30x250	39,5	250	Ø100	30	M30	28	289,5	69	15000

* Disponibile con Filettatura a passo fine. Aggiungere "/P2" al codice
Available with Thin pitch thread. Please, add "/P2" to the code

• Materiale base e stelo: acciaio zincato FE
Gomma vulcanizzata NBR 80 shore

• I valori dei carichi sopra riportati sono calcolati in condizioni statiche alla metà della lunghezza dello stelo filettato. Qualora s'intendesse utilizzare i supporti in presenza di vibrazioni o carichi in movimento, tali valori dovranno essere adeguatamente ridotti. Per ulteriori chiarimenti consultare il nostro ufficio tecnico.
Ogni nostra responsabilità decade in caso di manomissioni o modifiche dei componenti

• Base material: galvanized steel C40
Screw material: galvanized steel
Pad: vulcanized rubber NBR 80 shore

• Load values above mentioned have to be considered referring to static conditions calculated at the half of the screw length. In conditions of vibrations or in presence of dynamic loads these values should be reduced. For further information consult our technical office.
We cannot accept responsibility for mounts that have been tampered or modified

Morskate®

Gedreven door techniek



Any questions? Please contact us.

Morskate Aandrijvingen BV

Oosterveldsingel 47A
7558 PJ Hengelo (Ov)
The Netherlands

NL

T +31 (0)74 - 760 11 11
info@morskateaandrijvingen.nl
www.morskateaandrijvingen.nl

DE

T +49 692 - 222 34 95
info@morskateantriebstechnik.de
www.morskateantriebstechnik.de

EN

T +31 (0)74 - 760 11 11
info@morskatedrivetechnology.com
www.morskatedrivetechnology.com