

Plastic Modular Belt

Series **uni CPB** Type **20% Rough**

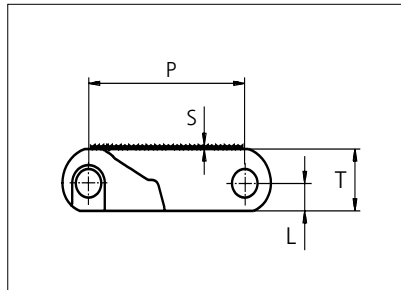

Straight running belt
 Nominal pitch: 50.8 mm (2.00 in)
 Surface type: Rough Top
 Surface opening: 20%
 Backflex radius: 85.0 mm (3.30 in)
 Pin diameter: ø8.0 mm (0.31 in)

Belt material & color	POM-NLAS K	POM-NL K	mm	in	mm	in		
			P (Nominal)	50.8	2.00	S	1.0	0.04
Pin material & color	PA6.6 N		L	8.0	0.31	T	18.0	0.71

Non standard material and color: See uni Material and Color Overview.

Alternative pin and lock materials: Lockpin: PBT **LG**

Belt width		Permissible tensile force (Belt/pin material)		Belt weight (Belt/pin material)		*Min. No. drive sprocket per shaft	Number of wear strips (Min. No.)	
		POM-NLAS / PA6.6 POM-NL / PA6.6		POM-NLAS / PA6.6 POM-NL / PA6.6			**Carry (pcs)	**Return (pcs)
mm	in	N	lbf	kg/m	lb/ft			
151	5.9	7852	1765	2.5	1.68	2	2	2
202	8.0	10504	2361	3.4	2.25	2	2	2
252	9.9	13104	2946	4.2	2.81	2	2	2
302	11.9	15704	3530	5.0	3.37	3	3	2
352	13.9	18304	4115	5.8	3.93	3	3	2
403	15.9	20956	4711	6.7	4.50	3	3	2
453	17.8	23556	5295	7.5	5.05	4	4	2
503	19.8	26156	5880	8.3	5.61	4	4	2
553	21.8	28756	6464	9.2	6.17	4	4	2
604	23.8	31408	7061	10.0	6.74	5	5	3
654	25.7	34008	7645	10.9	7.30	5	5	3
704	27.7	36608	8229	11.7	7.85	5	5	3
754	29.7	39208	8814	12.5	8.41	6	6	3

Additional standard belt widths are available in steps of 50.3 mm (1.98 in.) Additional non-standard belt widths are available in steps of mm 16.8 (0.66 in.)

1961	77.2	101972	22923	32.6	21.88	14	14	7
------	------	--------	-------	------	-------	----	----	---

Additional standard belt widths are available in steps of 50.3 mm (1.98 in.) Additional non-standard belt widths are available in steps of mm 16.8 (0.66 in.)

2966	116.8	154232	34671	49.2	33.09	20	20	10
------	-------	--------	-------	------	-------	----	----	----

General belt tolerance is +0/-0.4% at 23°C/73°F and 50% RH. For exact belt width contact Customer Service. Non standard belt width on request.

*Max. Load per Drive Sprocket. Belt material: POM-NLAS 2500 N (560 lbf), POM-NL 2500 N (560 lbf), PP 2500 N (560 lbf)

**Max. Spacing between wear strips, Carry: 152 mm (6 in.); Return: 304 mm (12 in.)

Any questions? Please contact us.

Morskate Aandrijvingen BV
 Oosterveldsingel 47A
 7558 PJ Hengelo (Ov)
 The Netherlands

NL
 T +31 (0)74 - 760 11 11
 info@morskateaandrijvingen.nl
 www.morskateaandrijvingen.nl

DE
 T +49 692 - 222 34 95
 info@morskateantriebstechnik.de
 www.morskateantriebstechnik.de

EN
 T +31 (0)74 - 760 11 11
 info@morskatedrivetechnology.com
 www.morskatedrivetechnology.com

STANDARD

STRAIGHT RUNNING

PITCH 50.8 MM/2.00 IN

Accessories

Rubber Top

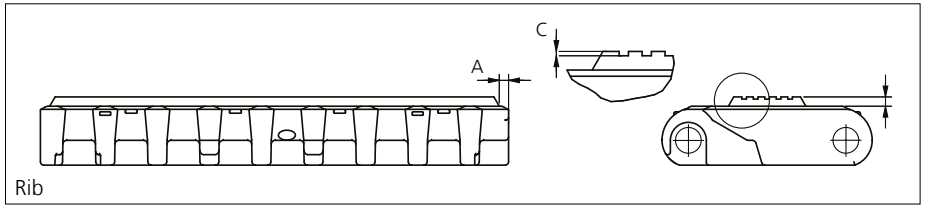
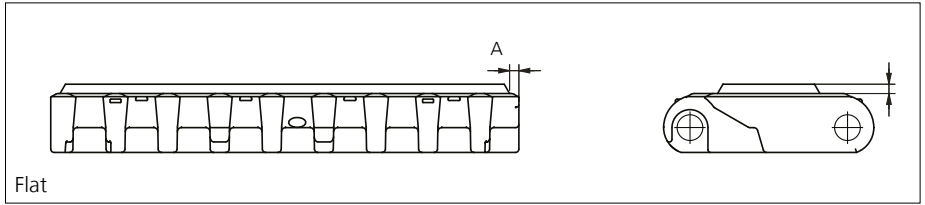

Type	Belt material & color	Rubber material & color	A		B		C		Link size	Width	
			mm	in	mm	in	mm	in		mm	in
Flat	POM-NL K	09 K	2.5	0.09	3.0	0.12	0.7	0.02	K600	150.5	5.93
Rib											

The color of standard rubber material is black. However, as it is hardly possible to see black rubber on black links, the links are illustrated with rubber in color natural. Other Non Standard Rubber profiles: See uni Rubber Profile Overview.

Accessories

Flight

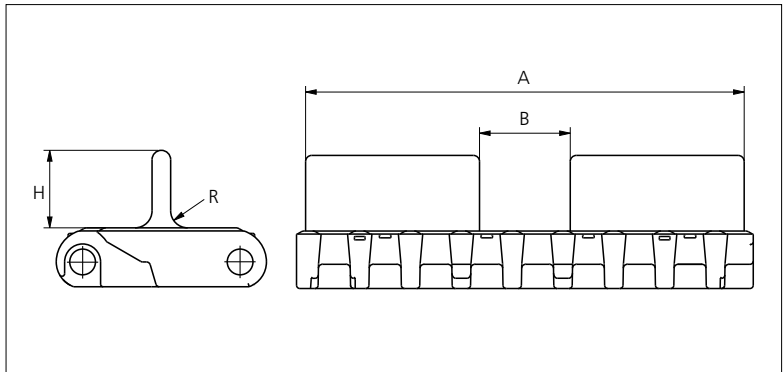
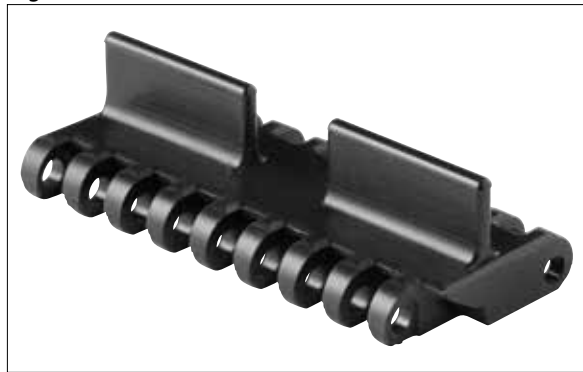

Type	Material & color	H		R		A		B		Link size	Width		Indent	
		mm	in	mm	in	mm	in	mm	in		mm	in	mm	in
Flat	POM-NLAS K	25.0	0.98	5.5	0.22	145.0	5.70	30.0	1.18	K600	150.5	5.93	2.8	0.11

Non Standard material and color: See uni Material and Color Overview.

Any questions? Please contact us.

Accessories

Top/Bottom Insert NON STANDARD



The thread inserts allow for easy attachment of fixturers to the belt.

Available insert size M5.

Depending on the size and shape of the attachment, attention should be paid as to how it will influence on the backflex radius of the belt.

Accessories

Non Standard uni AmFlight

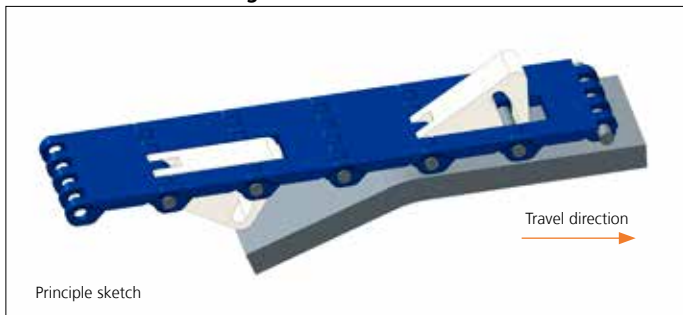

Principle sketch

Other Non Standard option: See uni AmFlight Overview.

Any questions? Please contact us.

Morskate Aandrijvingen BV

Oosterveldsingel 47A
7558 PJ Hengelo (Ov)
The Netherlands

NL

T +31 (0)74 - 760 11 11
info@morskateaandrijvingen.nl
www.morskateaandrijvingen.nl

DE

T +49 692 - 222 34 95
info@morskateantriebstechnik.de
www.morskateantriebstechnik.de

EN

T +31 (0)74 - 760 11 11
info@morskatedrivetechnology.com
www.morskatedrivetechnology.com

Sprocket

No of teeth	Bore size													Overall diameter		Pitch-diameter		Hub-diameter		A-dimension		B-dimension		Single row/One way	Double row/Two way	Molded PAG LG	Machined PAG N
	Pilot bore	in	0.75	0.78	0.98	1.00	1.18	1.25	1.50	1.57	2.36	2.50	3.54														
	mm	19.1	20.0	25.0	25.4	30.0	31.8	38.1	40.0	60.0	63.5	90.0	mm	in	mm	in	mm	in	mm	in							
Z06	x				●	●	●	■	■				99.5	3.92	101.6	4.00	65.0	2.56	36.0	1.42	59.3	2.33	x		x		
Z08	x				●	●	●	■	■				132.9	5.23	132.8	5.23	65.0	2.56	53.3	2.10	74.9	2.95	x		x		
Z10	x					●	●	■	■				166.3	6.55	164.4	6.47	65.0	2.56	70.2	2.76	90.7	3.57	x	x	x		
Z10										■	■		166.3	6.55	164.4	6.47	120.0	4.72	70.2	2.76	90.7	3.57	x	x	x		
Z12	x					●	●	■	■	■	■		198.6	7.82	196.3	7.73	120.0	4.72	86.8	3.42	106.6	4.20	x	x	x		
Z16	x					●	●	■	■	■	■		263.8	10.39	260.4	10.25	160.0	5.90	119.7	4.71	138.7	5.46		x	x		
Z16	x					●	●	■	■	■	■		263.8	10.39	260.4	10.25	150.0	5.90	119.7	4.71	138.7	5.46	x			x	

Non standard material and color: See uni Material and Color Overview.

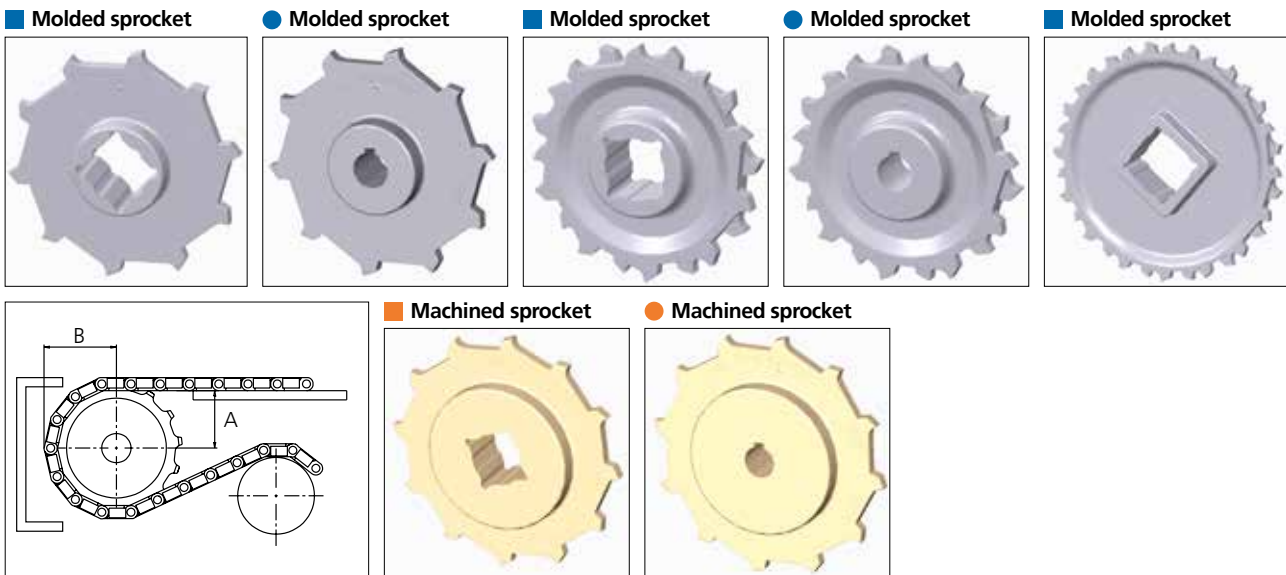

Other sprocket sizes are available upon request.

Two-part sprocket are available upon request.

Round bores are always delivered with keyway.

Other bore sizes are available upon request.

uni Retainer Rings: See uni Retainer Ring data sheet

Width of sprocket = Single row: 42.3 mm (1.66 in)

Double row: 50.0 mm (1.96 in)

Width of tooth = Single row: 9.5 mm (0.37 in)

Double row: 17.0 mm (0.66 in)

Max load per sprocket shown does not take bore size into account.

Please also ensure that sufficient size shaft is chosen for corresponding load.

For correct sprocket position: See uni Assembly Instructions for uni CPB.

For more detailed sprocket information, contact Customer Service.

Any questions? Please contact us.

Morskate Aandrijvingen BV

Oosterveldsingel 47A
7558 PJ Hengelo (Ov)
The Netherlands

NL
T +31 (0)74 - 760 11 11
info@morskateaanrijvingen.nl
www.morskateaanrijvingen.nl

DE
T +49 692 - 222 34 95
info@morskateantriebstechnik.de
www.morskateantriebstechnik.de

EN
T +31 (0)74 - 760 11 11
info@morskatedrivetechnology.com
www.morskatedrivetechnology.com